

Sept. 13, 1938.

G. A. PEATE

2,130,248

TUNER FOR STRING INSTRUMENTS

Filed Jan. 2, 1937

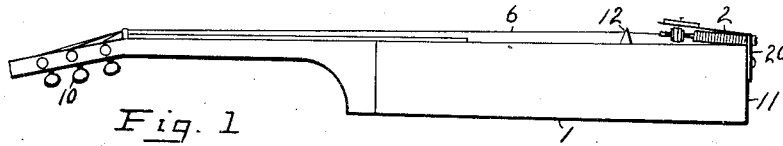

Fig. 1

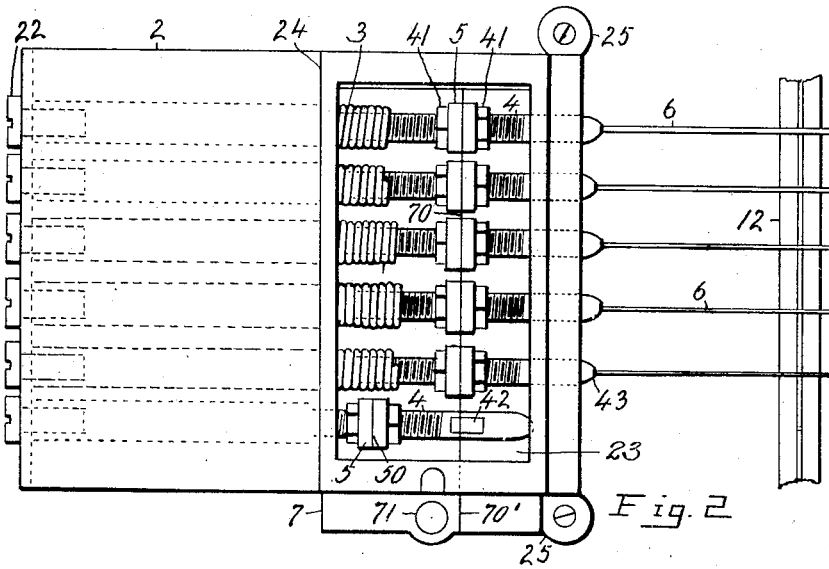

Fig. 2

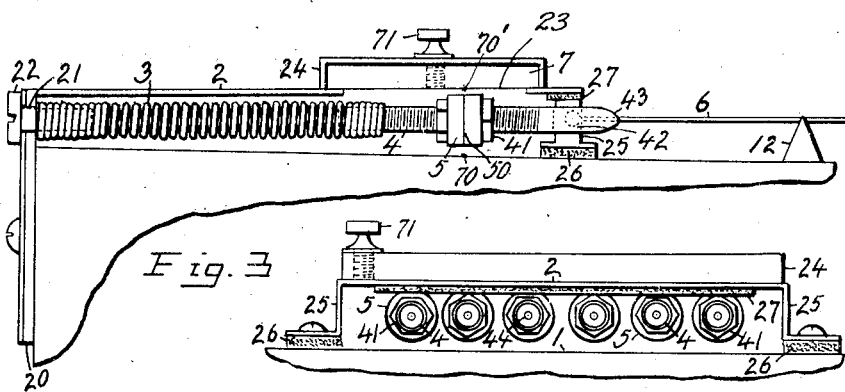

Fig. 3

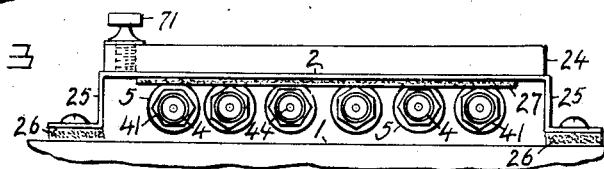

Fig. 4

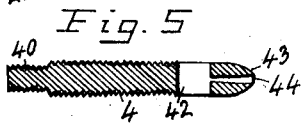

Fig. 5

INVENTOR

George A. Peate

By *Stanley A. Sudden*
ATTORNEY

UNITED STATES PATENT OFFICE

2,130,248

TUNER FOR STRING INSTRUMENTS

George A. Peate, Montreal, Quebec, Canada, assignor of one-third to Edmund H. Brietzcke, Westmount, Quebec, Canada

Application January 2, 1937, Serial No. 118,866

5 Claims. (Cl. 84—297)

This invention relates to the tuning of string instruments and particularly to providing means whereby the various strings of such instruments can be accurately tuned by mechanical adjustment and without any requirement of tuning by sound as hitherto commonly employed.

The object of the invention is to provide for string instruments a visual indicator of the tension of a string which when properly adjusted will result in the production of the tone required for the string with accuracy, rapidly and with ease.

A further object is to replace the uncertainty of unskilled tuning by ear and substitute a tested reliable mechanical adjustment.

This application covers a number of improvements over the invention of my Patent No. 2,070,196 dated February 16, 1937.

Reference is made to the accompanying drawing in which—

Figure 1 is a side view of a guitar mounted with the invention.

Figure 2 is a top view of one form of the mechanical features as applied to a guitar.

Figure 3 is a side view of the same.

Figure 4 is an end view as seen from the bridge.

Figure 5 is a sectional view of the form of the adjustment rod shown in Figures 2 and 3.

The instrument 1 has the usual tuning keys 10 at its upper end, and bridge 12. Secured to the lower end 11 is a metal plate 20 with a series of perforations 21 in the part projecting above the surface of the instrument 1. In the perforations 21 are a series of screws 22 which rotate freely therein. Each screw 22 after passing through a perforation 21 is screwed into the end of a coil spring 3, which is thus secured in position to the instrument 1. A series of rods 4 which have threaded ends 40 are screwed into the opposite ends of the coil springs 3. The rods 4 are also screw threaded for some distance beyond their junction with coil springs 3. Mounted on the threaded portion of the rods 4 are blocks 5 shown in the form of cylinders, which are freely movable on the rods 4. Adjustment nuts 41 meshing with the threaded rods 4 on either side of the blocks 5 provide a means of very accurate adjustment of the position of the blocks 5 on the rods 4. Other means of adjustment of the blocks 5 on the rods 4 may be employed within the scope of this invention. The blocks 5 are marked with marking lines 50. On the surface of the instrument 1 or on a transparent plate 7 mounted above the rods 4 is a fixed transverse marking line 70. The rods 4 are provided with means to

secure the ends of the strings 6. As shown in Figure 5 the rods 4 have pointed ends 43, and slots 42 connected by central bores 44, which widen towards the end 43. As shown in Figures 2 and 3, a cover plate 2 secured to the end plate 20 extends over the springs 3 and rods 4. A rectangular opening 23 in the plate 2 has a slideway 24, in which a transparent plate 7 slides transversely on the plate 2. This plate 7 carries the marking line 70 on its lower surface and is secured in position on the plate 2 by the set-screw 71. The front end of the plate 2 is supported on legs 25 secured through felt pads 26 to the surface of the instrument 1, and is thereby adjustable as to height. The front edge of the plate 2 may have a felt pad 27 across its lower surface. The plate 2 may in some cases be dispensed with, and when this is done, the marking line 70 is placed on the surface of the instrument below the rods 4. By having the transparent plate 7 adapted to slide over the aperture 23, access to the blocks 5 and adjustment nuts 41 is provided, should readjustment be required.

It is to be specially noted that from the bridge 12 to the end plate 20, the strings, rods and springs are entirely free from contact with anything. This prevents any jarring or rattling in the instrument.

The mode of operation is as follows:

When the device has been mounted on an instrument and the proper strings 6 have been inserted between the rods 4 and the tuning keys 10. The strings 6 are carefully and accurately tuned by sound in the usual way. The blocks 5 are then adjusted on the rods 4 with their marking lines 50 in line with the marking line 70, and secured in this position by the nuts 41. The instrument is then set for use and can leave the factory. As long as the marking lines 50 coincide with the marking line 70 the strings will be in correct tune. Should a string become loose or break its spring 3 will draw its block 5 and marking line 50 out of alignment. A broken string is replaced when necessary and the loose string is then tightened by its key 10 until its marking line 50 is brought to coincide with the marking line 70. The string will then be under the proper tension to produce its correct note.

This action is purely mechanical and is not dependent on sound. It can be carried out when or where sounds are inaudible.

What I claim is:

1. In a tuning device for stringed musical instruments, a tail piece secured to the instrument, a fixed transverse marking line on the instru-

ment, a series of tension coil springs secured to the tail piece at one end, rods secured to the springs at the other end, strings secured to the rods, a portion of the rods screw threaded, bored
5 markers on the rods free of the threading, and nuts meshing with the rods on each side of the markers.

2. In a tuning device for stringed musical instruments, a tail piece having a fixed mark, tension coil springs and rods, the springs secured
10 at one end to the tail piece and at the other end to rods, strings secured to the rods, a portion of the rods screw threaded, bored markers on the rods free of the threading, and nuts meshing
15 with the rods on each side of the markers.

3. In a tuning device for stringed musical instruments, a tail piece secured to the instrument at one end, having a transverse opening at the other end, a removable translucent plate mounted
20 to slide over the opening, a transverse marking line on the plate, tension coil springs secured at one end to the tail piece, rods secured to the springs at the other end under the plate, strings secured to the rods, a portion of the rods screw
25 threaded, bored markers on the rods free of the threading, and nuts meshing with the rods on each side of the markers.

4. In a tuning device for stringed musical in-

struments, a tail piece having a bent extension secured to the instrument at one end, having an opening across the tail piece at the other end, a removable translucent plate mounted to slide
5 over the opening having a transverse marking line on its lower surface, a series of tension coil springs secured to the extension of the tail piece at one end, rods secured to the springs at the other end, strings secured to the rods, and ad-
10 justable markers mounted on the rods free from the tail piece, adapted to be adjusted over the fixed marking line.

5. In a tuning device for stringed musical instruments, a tail piece having a bent extension secured to the instrument at one end, having an
15 opening in the tail piece across the other end, a removable translucent plate mounted to slide over the opening having a transverse marking line on its lower surface, a series of tension coil springs secured to the extension by screws
20 through perforations in its edge and in which they rotate freely, a series of rods secured to the springs, strings secured to the rods, a portion of the rods screw threaded, bored markers on the rods free of the threading and nuts to adjust
25 the position of the markers on the rods.

GEORGE A. PEATE.